

DOUBLE ACTING
"ADA"

SPRING RETURN
"ASR"

Item	Description	Material	Item	Description	Material
1	Body	Aluminium Hard Anodized	23	Centering Ring	Nickel Plated Carbon Steel
2	Piston	Aluminium	24	Plug Air Stop	NBR
3	Pinion	Nickel Plated Carbon Steel	25	Slide Guide	Resin
4	End Caps	Aluminium Epoxy Coated	26	Lower Pinion Bearing	Hostalen
5	Soft Pinion Washer	Nylon 6.6	109	O-Ring	NBR
6	Slide Piston	Polyamide	110	O-Ring	NBR
8	Pinion Washer	Stainless Steel	111	O-Ring	NBR
10	Upper Pinion Bearing	Hostalen	113	Bolt	Stainless Steel
12	Stop	A-216 WCB	118	O-Ring	NBR
14	(*) Spring's Long Support	Nylon 6.6	119	O-Ring	NBR
15	(*) Spring's Short Support	Nylon 6.6	125	Washer	Stainless Steel
16	Leveling Screw	A4 -70	913	Set Screw	Stainless Steel
18	(*) Bolt	Stainless Steel	471	External Circlip	Stainless Steel
19	(*) Spring	DIN 2076 -D-5.6	934	Nut	Stainless Steel
20	Position Indicator	Polyamide	985	(*) Nut	Stainless Steel
21	Cam	Polyamide			

(*) Only for serie **ASR**

Dimensions

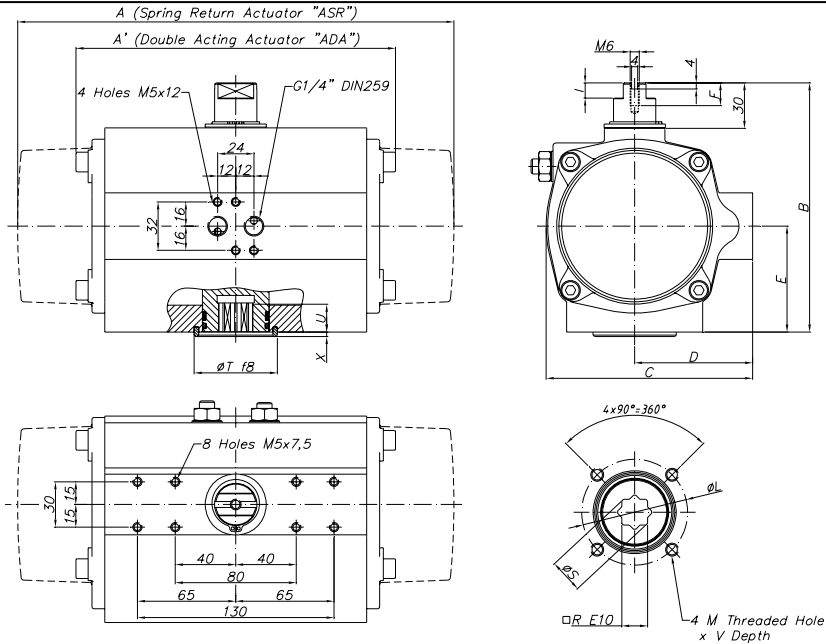

A	A'	B	C	D	E	F	I	R	ØS	ISO 5211	ØL	M x V	ØT	X	U
601	461	280	242,5	131	130	16	15	36	48,5	F14	140	M16x26	100	4	50

(*) Dimensions in mm

GENERAL CHARACTERISTICS	Serie ADA	Actuator	Double	Acting
	Serie ASR	Actuator	Spring	Return
DESIGN STANDARDS				
Mounting of solenoid valves	NAMUR Std.			
Mounting of devices	NAMUR VDI	NAMUR VDE 3845 Std.		
Coupling according	ISO 5211	DIN 3337		
Marking	CE	II 2 G D c LCIE 05 AR 022		
TESTS AND CERTIFICATES				
Quality Assurance	ISO 9001			

Max. Pressure	Rotation	Screw stroke Adjustment	Chamber Ø (mm)	Air Volume (L)		Stroke Time (Sec. (A))		Operating Temperature (°C) (B)		
				Opening	Closing	Opening	Closing	STD (standard)	HT (high temp.)	LT (low temp.)
8 bar	90° ±5°	For 1° Need 1/3 Turn	210	9,8	9,3	D 1,8	D 2,0	NBR "O" Ring	FPM "O" Ring	Silicone "O" Ring
						S 2,8	S 3,2	-20° to +80°	-15° to +150°	-40° to +80°

Double Acting Actuator "ADA" Torque Output in Nm

TYPE	Output Torque For Double Acting in Nm										Weight (Kg)								
	3 bar		3,5 bar		4 bar		4,5 bar		5 bar			5,5 bar		6 bar		6,5 bar		7 bar	
D	707	824	942	1060	1178	1295	1413	1531	1649	1884	32,5								

Spring Return Actuator "ASR" Torque Output in Nm

TYPE	Output Torque For Spring Return in Nm																Spring stroke		Weight (Kg)				
	3 bar		3,5 bar		4 bar		4,5 bar		5 bar		5,5 bar		6 bar		6,5 bar		7 bar			8 bar		END	STAR
S06	477	349	595	466	712	584	830	702	948	820	1066	937	1183	1055	1301	1173	1419	1291	1654	1526	270	421	39,3
S08	400	229	518	347	636	465	754	582	871	700	989	818	1107	936	1225	1053	1342	1171	1578	1407	360	562	41,0
S10			441	228	559	345	677	463	795	581	912	699	1030	816	1148	934	1266	1052	1501	1287	451	702	42,7
S12 (A)							600	344	718	461	836	579	954	697	1071	815	1189	933	1425	1168	541	843	44,4
S14									642	342	759	460	877	578	995	695	1113	813	1348	1049	631	983	46,0